



WARNING

Switch off the supply voltage before working on the relay or connecting or disconnecting it with other devices or PC. Switch the supply voltage on only after all works have been completed.



CAUTION

Observe power supply polarity when connecting the relay to 24 V DC power source. Reverse polarity may cause the relay damage.



CAUTION

The program loaded to the relay runs immediately after switching the relay ON or the relay reset. It is highly recommended to make sure all connections to peripheral device are safe. Otherwise make sure that all peripheral devices are disconnected from relay outputs before loading the program.

1. Specifications

Table 1 General specification

Parameter	Value
Power supply	
Voltage range	20..27 VAC, 50 Hz
Nominal supply voltage	24 V DC
Power consumption, max.	8 W
Digital inputs	
Number	6
Nominal supply voltage	24 V DC
Maximum permissible supply voltage	30 V DC
Fast digital inputs	
Number	2
Digital / Analog inputs	
Number	4
Signal type	4...20 mA, 0...10 V, 0...300 kΩ
Digital outputs	
Number	8
Type	Relay (NO)
Analog outputs	
Number	3
Signal type	4...20 mA and 0...10 V
Network interfaces	
Types	1×Ethernet and 2×RS485
General	
Mounting	DIN-rail (35 mm)
Dimensions	123 × 90 × 57 mm
IP Code	IP20
Weight	approx. 600 g
Average service life	8 years

2. Operating conditions

The device is designed for natural convection cooling that should be taken into account when choosing the installation site.

The following environmental conditions must be observed:

- clean, dry and controlled environment, low dust level
- closed non-hazardous areas, free of corrosive or flammable gases

Table 2 Environmental conditions

Condition	Permissible range
Ambient temperature	-20...+55 °C
Relative humidity	up to 80 % (at +35 °C, non-condensing)
Transportation and storage temperature	-25...+55 °C
Altitude	up to 2000 m above sea level
EMC immunity	conforms to IEC 61000-6-2
EMC emission	conforms to IEC 61000-6-4

3. Installation

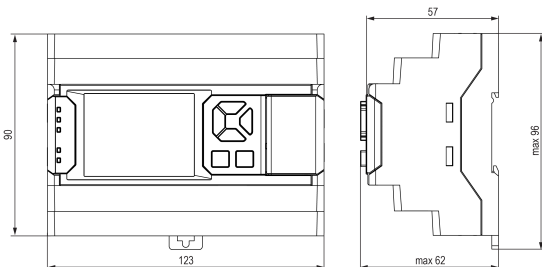

Fig. 1 - Dimensions

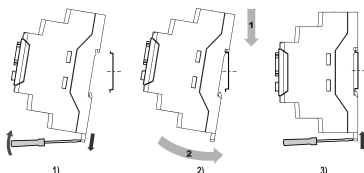

Fig. 2 - Installation

Installation:

1. Place the device on a DIN rail as shown in Fig. 2.
2. Press the device firmly against the DIN rail in the direction of arrow 2 until the latch locks.
3. Wire the device using the supplied terminal blocks.

Removing:

1. Take off the terminal blocks without disconnecting wires.
2. Insert a screwdriver into the eyelet of the slide interlock.
3. Loosen the slide interlock and then remove the relay from the DIN rail.

The relay is equipped with plug-in terminal blocks which enable quick replacement of the device without disconnecting the existing wiring.

4. Digital inputs

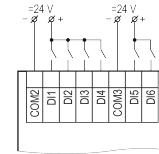

Fig. 3 - Switch contacts wiring (24 V AC)

5. Analog inputs

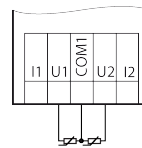

Fig. 4 - RTD sensors wiring

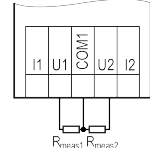

Fig. 5 - Resistance sensors wiring

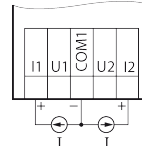

Fig. 6 - Current sensors wiring

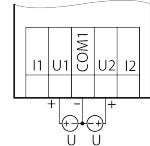

Fig. 7 - Voltage sensors wiring

6. Fast digital inputs

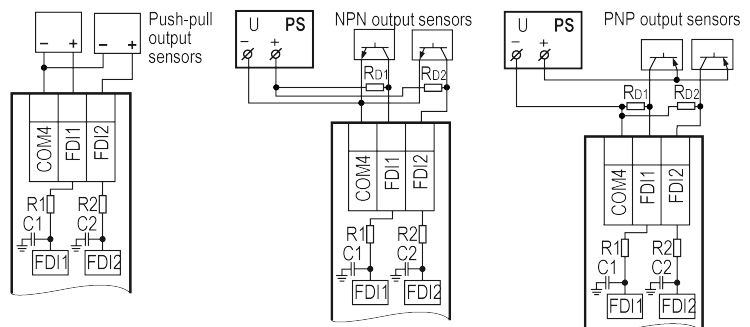

Fig. 8 - Fast digital inputs wiring

7. Output wiring

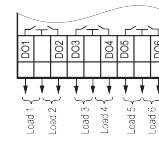

Fig. 9 - Relay outputs

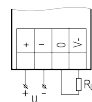

Fig. 10 - Current output wiring

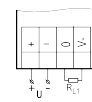

Fig. 11 - Voltage output wiring

8. RS485 interface

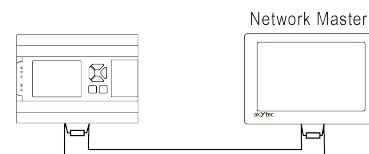

Fig. 12 - PR205 as Slave

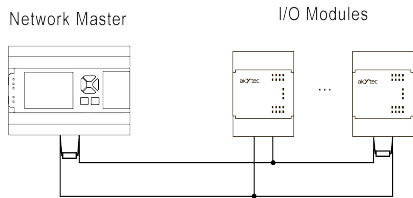

Fig. 13 – PR205 as Master

9. Ethernet interface

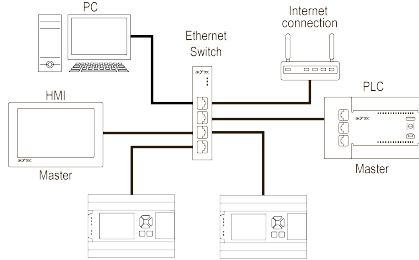

Fig. 14 – Star topology

10. Extension modules

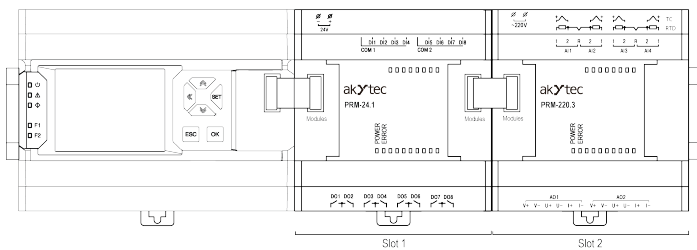

Fig. 15 – Extension modules connection

11. Controls and interfaces

- color graphic LCD
- six buttons
- five LEDs
- cover
- Under the cover:
 - extension module connector
 - Run/Stop switch
 - microUSB programming connector

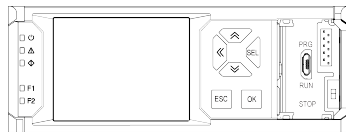

Fig. 16 – The front panel (the cover on the right is open)

Table 3 Buttons

Button	Description
View mode	
↔ and ↕	Screen navigation. Move to the next screen when the selected area is on the border of the current screen.
⏩ + ↕	To the next screen from anywhere on the current screen.
⏪ + ↕	To the previous screen from anywhere on the current screen.
OK	Press and hold for 6 seconds to enter the system menu.
ESC	Press and hold for 6 seconds to exit the system menu.
Edit mode	
⏩	Enter the edit mode on the current screen. When pressed, the first editable element on the screen becomes available for editing and starts flashing. Apply a value and move to the next parameter.
↔ and ↕	Change the parameter value. Press and hold to accelerate the value change.
⏪	Move to a higher level. When moving to the maximum level, it jumps to the lowest one.
⏩ + ↕	Move to a lower level.
⏪ + ↕	Move to a higher level.
ESC	Exit the edit mode without saving the edited value.
OK	Exit the edit mode and save the edited value.

Table 4 Indicators

LED	Color	Status	Description
⏻	green	ON	The device is powered on
⚠	red	ON	Failure in the device. Contact the service center
		Flashing	
F1	green	—	To be defined by user's program
F2	red	—	

LED	Color	Status	Description
⚠	red	OFF	Stop
	green	Flashing	
	red	ON	No power on terminals 1 and 2. Powered by USB.
	green	OFF	
	red	OFF	Run
	green	ON	
	red	Flashing*	Run
green	ON		
red	OFF	Stop	
green	Flashing*		
red	Flashing with a period	Error	
red	Flashing	Boot is in progress	

* Flashing together with ⚠ means that the RTC battery is discharged

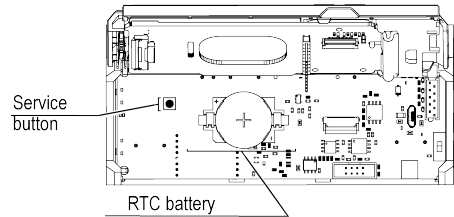

Fig. 17 – Under the front panel

12. Device menu

The device has a user menu and a system menu. The user menu is created in ALP with the help of **Display Manager**. To specify "jumps", use buttons or change a variable. The system menu is always present in the device, even if there is no user program written to it.

It is possible to work with the menu in View and Edit modes. In the **View** mode, you can view the device parameters or the user menu. In the **Edit** mode, you can edit the device parameters in the system menu or the user program from the front panel without stopping the device. When you re-enter the Edit mode, the last edited element is selected.