



## MU110-24.32R

### Digital output module 32 channel

### User guide

MU110-24.32R\_3-EN-145547-1.1  
© All rights reserved  
Subject to technical changes and misprints

## Contents

<b>1. Introduction</b> .....	<b>2</b>
1.1. Abbreviations .....	2
1.2. Symbols and key words.....	2
1.3. Intended use .....	2
1.4. Limitation of liability .....	2
1.5. Safety .....	2
<b>2. Overview</b> .....	<b>4</b>
2.1. Basic features .....	4
2.2. Design and indication .....	4
<b>3. Specifications</b> .....	<b>5</b>
3.1. Specifications .....	5
3.2. Operating conditions .....	5
<b>4. Configuration and operation</b> .....	<b>6</b>
4.1. Operation modes .....	7
4.2. Functional test .....	7
4.3. Individual control in PWM mode .....	7
4.4. Group control .....	8
4.5. Fault condition .....	8
4.6. RS485 network .....	8
4.7. Modbus registers .....	9
4.8. Hardware write protection of permanent memory .....	10
<b>5. Installation</b> .....	<b>11</b>
5.1. Mounting.....	11
5.2. Wiring .....	11
5.2.1. Outputs .....	11
<b>6. Factory settings restoration</b> .....	<b>14</b>
<b>7. Maintenance</b> .....	<b>16</b>
<b>8. Transportation and storage</b> .....	<b>17</b>
<b>9. Scope of delivery</b> .....	<b>18</b>
<b>Appendix A. Appendix A. Dimensions</b> .....	<b>19</b>
<b>Appendix B. Galvanic isolation</b> .....	<b>20</b>

## 1 Introduction

### 1.1 Abbreviations

**MX110\_configurator** – configuration software

**Modbus** – application layer messaging protocol for client/server communication between devices connected on different types of buses or networks, originally published by Modicon (now Schneider Electric), currently supported by an independent organization Modbus-IDA ([www.modbus.org](http://www.modbus.org))

### 1.2 Symbols and key words

**WARNING**

**WARNING** indicates a potentially dangerous situation that could result in death or serious injuries.

**CAUTION**

**CAUTION** indicates a potentially dangerous situation that could result in minor injuries.

**NOTICE**

**NOTICE** indicates a potentially dangerous situation that could result in damage to property.

**NOTE**

**NOTE** indicates helpful tips and recommendations, as well as information for efficient and trouble-free operation.

### 1.3 Intended use

The device has been designed and built solely for the intended use described here, and may only be used accordingly. The technical specifications contained in this document must be observed. The device may be operated only in properly installed condition.

### Improper use

Any other use is considered improper. Especially to note:

- The device may not be used for medical applications.
- The device may not be used in explosive environment.
- The device may not be used in atmosphere in which there are chemically active substances.

### 1.4 Limitation of liability

Our company does not bear any responsibility with respect to breakdowns or damages caused by using the product in a manner other than described in the Manual or in violation of the current regulations and technical standards.

### 1.5 Safety

**WARNING**

**WARNING** Ensure the mains voltage matches the voltage marked on the nameplate. Ensure the device is provided with its own power supply line and electric fuse.

**WARNING**

**WARNING** The device terminals may be under a dangerous voltage. De-energize the device before working on it. Switch on the power supply only after completing all works on the device.

**NOTICE**

**NOTICE** Supply voltage may not exceed 28 V. Higher voltage can damage the device. If the supply voltage is lower than 20 V DC, the device cannot operate properly but will not be damaged.

**NOTICE**

*If the device is brought from a cold to a warm environment, condensation may form inside the device. To avoid damage to the device, keep the device in the warm environment for at least 1 hour before powering on.*

## 2 Overview

### 2.1 Basic features

Digital output module MU110-24.32R is an extension module with 32 digital outputs. The module has the following functions:

- Connection of actuators with digital outputs
- Output control using Modbus network
- Pulse width modulation (see [Table 4.2](#))
- Network diagnostics
- Fault and alarm signals
- Slave in a Modbus protocol structure

The module uses Modbus-RTU and Modbus-ASCII protocols with automatic protocol identification. The module can be configured with the [Mx110 Configurator](#) software using an RS485-USB interface adapter (not included). The latest version of the configuration software is available for download on [www.akytec.de](http://www.akytec.de).

### 2.2 Design and indication

Table 2.1 Indication

LED	LED state	Description
POWER	ON	Power on
RS485	Flashing	Data exchange via RS485 interface
FAULT	ON	Data exchange via RS485 interface is interrupted
OUTPUT 1...32	ON	Output is on

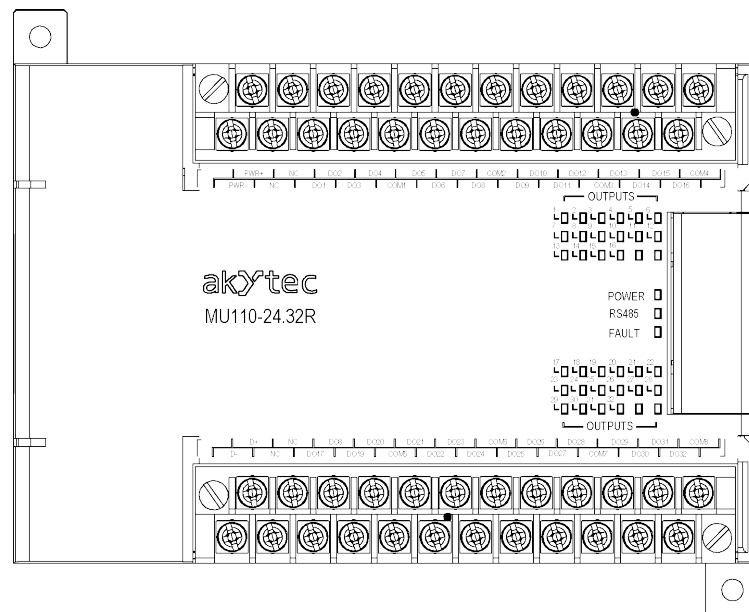

Fig. 2.1 Front view of MU110-24.32R

Dimensional drawings are given in [App. A](#).

There are three DIP-switches under the module front cover (see [Fig. 5.1](#)):

- 1 – restore factory settings (see [Section 6](#))
- 2 – service function
- 3 – DRAM write-protection (see [Section 4.8](#))

All switches are in OFF position by default.

## 3 Specifications

### 3.1 Specifications

Table 3.1 Specifications

Parameter		Value
Power supply		24 (20...28) V DC
Power consumption, max.		20 W
Inputs	digital	–
	analog	–
Outputs	digital	32
	analog	–
RS485 interface	Connection	D+, D-
	Protocols	Modbus RTU/ASCII
	Baud rate	2.4...115.2 kbit/s
	Data bits	7, 8
	Parity	odd, even, none
	Stop bits	1, 2
Dimensions		140 × 114 × 75 mm
Weight, max.		800 g
Material		plastic
IP code		IP20

Table 3.2 Technical data of outputs

Parameter	MU110-24.32R
Output	relay (NO)
Permissible load	3 A, 250 V AC, $\cos \varphi > 0.4$ or 3 A, 30 V DC

### 3.2 Operating conditions

The module is designed for natural convection cooling that should be taken into account when choosing the installation site.

The following environmental conditions must be observed:

- clean, dry and controlled environment, low dust level
- closed non-hazardous areas, free of corrosive or flammable gases

Table 3.3 Operating conditions

Condition	Permissible range
Ambient temperature	-20...+55°C
Transportation and storage	-25...+55°C
Relative humidity	up to 80% (at +25°C, non-condensing)
Altitude	up to 2000 m above sea level

## 4 Configuration and operation



### NOTE

Before switching on, make sure that the device was stored at the specified ambient temperature (**-20 ... +55 °C**) **for at least 60 minutes**.

Parameters of the module can be read, edited and saved with the Mx110 Configurator software. The full list of parameters is shown in [Table 4.1](#).

The software and its user guide can be found on the [akYtec](#) site.

The module should be configured first before operating in the RS485 network.

The following steps are required:

1. Install the Mx110 Configurator on the PC.
2. The module should be connected to the USB-port of the PC over a USB/RS485 adapter (not included). Connect the D+/D- terminals of the module with the D+/D- contacts of the adapter.
3. Connect the power supply to the 24V/0V terminals of the module.
4. Turn on the power supply.
5. Start the Mx110 Configurator.

If the factory settings of the module have not been changed, the connection to the module is automatically established, the module is automatically recognized, its configuration parameters are read out and an appropriate configuration mask opens.

If it does not happen, parameters of the configurator have to be changed.

*Table 4.1 Configuration parameters*

Name	Parameter	Valid value	Meaning	Default settings
<b>Basic parameters</b>				
<b>dev</b>	Device	Up to 8 symbols		MU110-24.32R
<b>ver</b>	Firmware version	Up to 8 symbols		manufacturer
<b>Network parameters</b>				
<b>bPS</b>	Baud rate, kbit/s	0	2.4	9.6
		1	4.8	
		2	9.6	
		3	14.4	
		4	19.2	
		5	28.8	
		6	38.4	
		7	57.6	
		8	115.2	
<b>LEn</b>	Data bits*	0	7	8
		1	8	
<b>PrtY</b>	Parity*	0	none	none
		1	even	
		2	odd	
<b>Sbit</b>	Stop bits*	0	1	1
		1	2	
<b>A.Len</b>	Address bits	0	8	8
		1	11	

## 4 Configuration and operation

Name	Parameter	Valid value	Meaning	Default settings
<b>Addr</b>	Device address	1...247		16
<b>t.out</b>	Time-out, s	0...600		0
<b>Rs.dL</b>	Response delay, ms	0...45		2
<b>Output parameters</b>				
<b>THPD</b>	PWM period, s	1...900		1
<b>O.ALr</b>	Safe output status, %	0...100		0



### NOTE

\* Invalid network parameter combinations:

- *prty=0; sbit=0; len=0*
- *prty=1; sbit=1; len=1*
- *prty=2; sbit=1; len=1*

### 4.1 Operation modes

In the operation mode the module is controlled by a network Master in the Modbus network. It can be performed in different ways:

- Individual control in PWM mode (see [Section 4.3](#))
- Group control (see [Section 4.4](#)).

Modbus functions 03, 04 can be used for reading and 15, 16 can be used for writing.

### 4.2 Functional test

To test the module for proper functioning the following steps are required:

- Connect the module to a USB-port of the PC using a USB/RS485 adapter.
- Start the Mx110 Configurator on the PC.
- If the connection has not been established automatically, the network parameters of the configurator have to be changed.
- Choose menu item 'Device -> I/O status...'. A new window "Output status" will open.
- For each output the PWM duty cycle (pulse to period ratio) between 0 and 1 can be set, so that output is switched on/off or a continuous pulse train is generated.
- Output resistance for MU110-24.32R modification can be optionally measured with an ohmmeter.
  - Max resistance on closed outputs = 1  $\Omega$
  - Min resistance on open outputs = 2 M $\Omega$
- If there are any deficiencies in functioning, contact the akYtec service staff.

### 4.3 Individual control in PWM mode

Average voltage can be changed using pulse width modulation (PWM). Pulses with the specified period (parameter **THPD**) and the duty cycle (pulse to period ratio) are generated on the output. Possible output statuses depending on duty cycle are shown in [Table 4.2](#). Modbus function 16 should be used to transfer the duty cycle value to the module.

Table 4.2 Pulse width modulation

Duty cycle		Output status
in configuration	in Modbus command	
0	0	0

## 4 Configuration and operation

1	1000	1
between 0 and 1	between 0 and 1000	between 0 and 1

- The configurator uses not the Modbus protocol but its own internal communication protocol. Therefore, range of value in configuration and in a Modbus command can differ. For example, the duty cycle must be set to 1 for switching on the DO1 output during the functional test. In a Modbus command the duty cycle must be written as 0001 in register 0000.
- The PWM period (**THPD**) is usually set during the configuration. The period can also be changed by a Modbus command, and the following should be noted:



### NOTE

Permanent memory

As the permanent memory is not unlimited rewritable (approx.  $10^6$  times), it is not advisable to change the parameters 'THPD' (PWM period) and 'O.ALr' (Safe output status) by Modbus commands as often as, for instance, the PWM duty cycle.

- The minimum PWM period is 50  $\mu$ s and cannot be changed.

### 4.4 Group control

Group control is performed using Modbus function 16.

Thus, the output status bitmask (see [Table 4.3](#)) has to be written into register 50 (0x0032). This way all outputs can be controlled simultaneously. Bit 0 corresponds to output 1.

With the transfer of the mask, the generation of the pulse is stopped and the outputs are set in accordance with the mask.

### 4.5 Fault condition

If the data exchange via the serial port is interrupted (i. e. there is no command from the master within the time specified by the **t.out** parameter) all outputs are set to a safe status. 'Fault Condition' is a combination of all safe PWM duty cycle values set in the **O.ALr** parameter (Safe output status) for each output.

In this case:

- LED FAULT flashes.
- A request from the master device terminates the Fault Condition.
- Outputs remain in the safe status until a command from the master changes the output status.
- If the **t.out** parameter is set to 0, 'Fault Condition' is not defined.

Parameters **t.out** and **O.ALr** can be set during configuration or operation. The 'Permanent memory' note in [Section 4.3](#) should be taken into account.

### 4.6 RS485 network

The I/O modules of series Mx110 use the common RS485 standard for data exchange.

The RS485 serial interface enables communication via a two-wired line in the half-duplex mode. The modules support Modbus RTU and Modbus ASCII protocols. The network consists of a Master device and can contain up to 32 Slave devices. The maximum length is 1200 m. The number of Slave devices and the network length can be increased using an RS485 interface repeater.

Devices are connected to a network according to linear (bus) topology. It means that the line goes from the first device to the second one, from the second one to the third one, etc. Star connection and spur lines are not allowed.

Line reflections always occur at each of the 2 ends of the bus (the first and the last node). The higher the data transmission rate, the stronger they are. A terminating resistor is needed to minimize reflections. Line termination may be a 150  $\Omega$  value (0.5 W) resistor.

All modules can be used as Slave devices only. The Master device can be a PLC, a computer with SCADA software or a control panel.

## 4 Configuration and operation

### 4.7 Modbus registers

All variables and parameters in *Table 4.3* are of the UINT16 type.  
Variables in *Table 4.4* are of the BOOL type.

R – read access.

W – write access

*Table 4.3 Modbus registers*

Parameter	Unit	Value		Access	Address	
		Config-uration	Modbus command		hex	dec
Duty cycle DO1	-	0...1	0...1000	RW	0000	0000
Duty cycle DO2	-	0...1	0...1000	RW	0001	0001
Duty cycle DO...	-	0...1	0...1000	RW	...	...
Duty cycle DO32	-	0...1	0...1000	RW	001F	0031
Safe output status (O.ALr) DO1	-	0...100	0...1000	RW	0020	0032
Safe output status (O.Alr) DO2	-	0...100	0...1000	RW	0021	0033
Safe output status (O.Alr) DO...	-	0...100	0...1000	RW	...	...
Safe output status (O.Alr) DO32	-	0...100	0...1000	RW	003F	0063
PWM period (THPD) DO1	s	1...900	1...900	RW	0040	0064
PWM period (THPD) DO2	s	1...900	1...900	RW	0041	0065
PWM period (THPD) DO...	s	1...900	1...900	RW	...	...
PWM period (THPD) DO32	s	1...900	1...900	RW	005F	0095
Time-out (t.out)	s	0...600	0...600	RW	0030	0048
Output status bitmask	-	-	0... 4294967295	RW	0032	0050

*Table 4.4 Output status binary addresses for Modbus function 15*

Output	Access	Address	
		hex	dec
1	W	0000	0000
2	W	0001	0001
...	W	...	...
32	W	001F	0031

### 4.8 Hardware write protection of permanent memory

The data in permanent memory may be lost because of strong electromagnetic interferences or similar conditions. Switch 3 (hardware write protection) makes it possible to avoid data loss.

The following steps are required:

1. Turn off the power supply.
2. Open the front cover of the module (see [Fig. 5.1](#)).
3. Set DIP-switch 3 to ON.

Thereby the following is to be observed:

- In order to change configuration parameters, the switch should be set to OFF.

### 5 Installation

#### 5.1 Mounting

**WARNING**

*Improper installation can cause serious or minor injuries or device damage. Installation must be performed only by fully qualified personnel.*

The device is designed for DIN-rail or wall mounting in a cabinet. See dimensional drawings in Appendix A.

Install the module in the cabinet with clean, dry and controlled environment. The operating conditions from the [Sect. 3.2](#) must be considered when choosing the installation site.

The device has been designed for natural convection cooling. Make sure that the cabinet provides sufficient clearance for natural convection.

#### 5.2 Wiring

**WARNING**

*Electric shock could kill or seriously injure*

**WARNING**

*All electrical connections must be performed by a fully qualified electrician. Ensure that the mains voltage matches the voltage marked on the nameplate! Ensure that the device is provided with an electric fuse!*

**NOTE**

*Switch on the power supply only after the wiring of the device has been completely performed.*

Connect power supply to the 24V / 0V terminals.

The maximum conductor cross-section for power supply is 1.5 mm<sup>2</sup>.

**NOTE**

EMC safety

Signal cables should be routed separately or screened from the supply cables.

Only a shielded cable may be used for signal lines.

Connect the RS485 cable to terminals D+ and D-.

Connection to the RS485 interface is carried out via a twisted pair cable.

##### 5.2.1 Outputs

- Module MU110-24.32R has 32 relay outputs.
- Outputs can be controlled via the RS485 network.
- Each output can be operated in the pulse width modulation mode (PWM).
- Output technical data are shown in [Table. 3.2](#)

**NOTE**

Make sure that voltage and current on the outputs do not exceed maximum values even briefly.

If voltage rises, especially when inductive load (relay, coil etc.) is connected, keep the voltage peaks limited by protective measures.

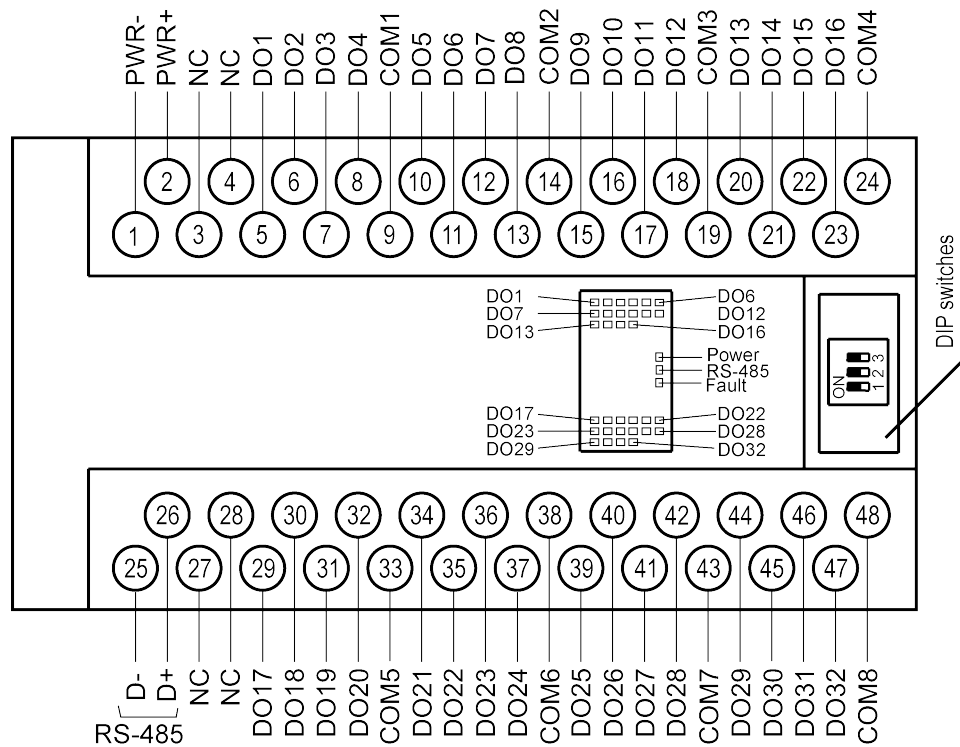

Fig. 5.1 Electrical connections

Table 5.1 Terminal assignments of MU110-24.32R

No	Name	Description	No	Name	Description
1	0V	Power supply	25	D-	RS485 D-
2	24V		26	D+	RS485 D+
3	NC	Not connected	27	NC	Not connected
4	NC	Not connected	28	NC	Not connected
5	DO1	Output 1	29	DO17	Output 17
6	DO2	Output 2	30	DO18	Output 18
7	DO3	Output 3	31	DO19	Output 19
8	DO4	Output 4	32	DO20	Output 20
9	COM1	Common negative for outputs 1-4	33	COM5	Common negative for outputs 17-20
10	DO5	Output 5	34	DO21	Output 21
11	DO6	Output 6	35	DO22	Output 22
12	DO7	Output 7	36	DO23	Output 23
13	DO8	Output 8	37	DO24	Output 24
14	COM2	Common negative for outputs 5-8	38	COM6	Common negative for outputs 21-24
15	DO9	Output 9	39	DO25	Output 25

16	DO10	Output 10	40	DO26	Output 26
17	DO11	Output 11	41	DO27	Output 27
18	DO12	Output 12	42	DO28	Output 28
19	COM3	Common negative for outputs 9-12	43	COM7	Common negative for outputs 25-28
20	DO13	Output 13	44	DO29	Output 29
21	DO14	Output 14	45	DO30	Output 30
22	DO15	Output 15	46	DO31	Output 31
23	DO16	Output 16	47	DO32	Output 32
24	COM4	Common negative for outputs 13-16	48	COM8	Common negative for outputs 29-32

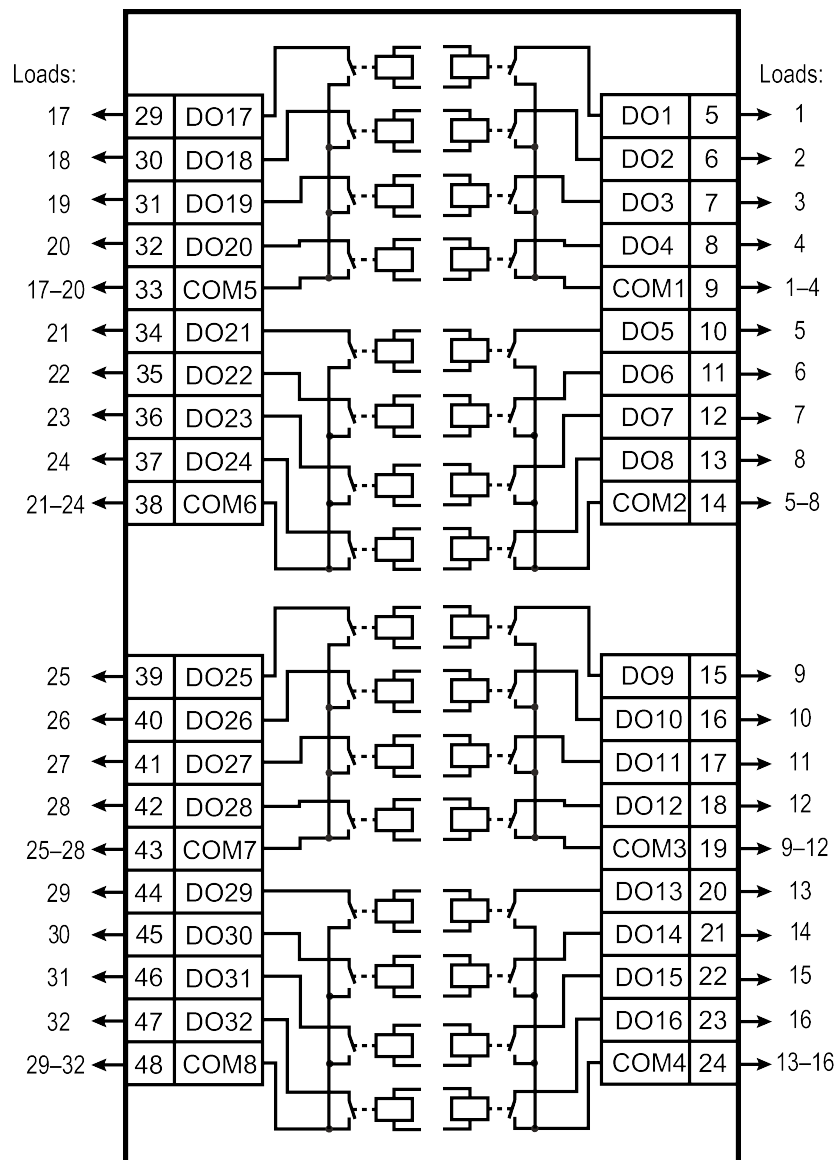

Fig. 5.2 MU110-24.32R outputs

## 6 Factory settings restoration

If communication between the module and a PC cannot be established and network parameters of the module are unknown, the default network settings should be restored. The following steps are required:

1. Turn off the power supply.
2. Remove the left front cover of the module.
3. Set DIP-switch 1 to ON. The module will operate with the default network parameters, the user settings are saved.
4. Turn on the power supply again.

**WARNING**

The voltage on some components of the circuit board can be dangerous. Direct contact with the circuit board or penetration of any foreign body in the enclosure must be avoided!

5. Start the Mx110 Configurator.
6. In the 'Connection to device' window, enter the values from [Table 6.1](#) or click 'Use factory settings'.

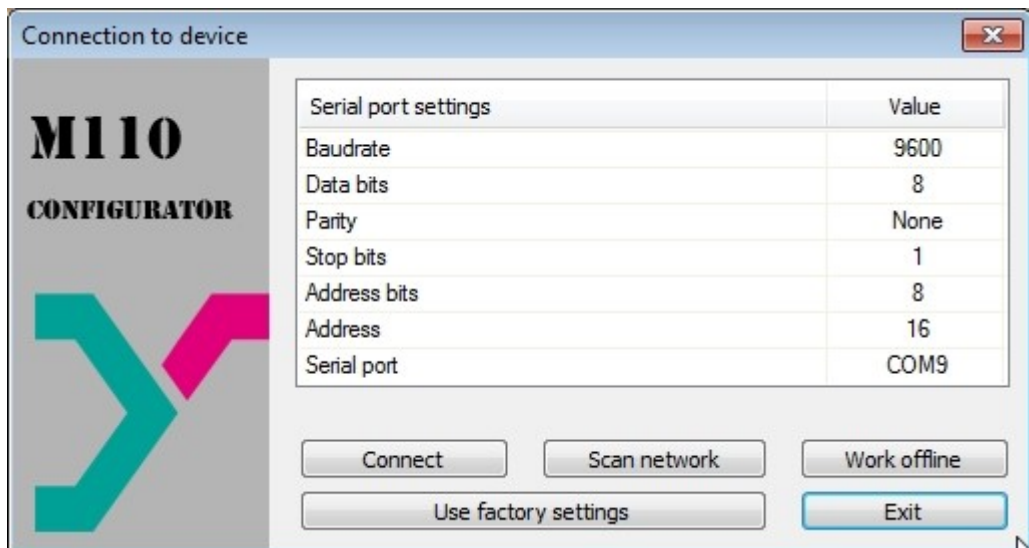

Fig. 6.1 Mx110 Configurator start window

7. Click 'Connect' to establish the connection with factory settings.
8. The main window of the Configurator opens. Saved user parameters of the module can be read now (see [Fig. 6.2](#)).
9. Open folder 'Network parameters' and note the user network parameters

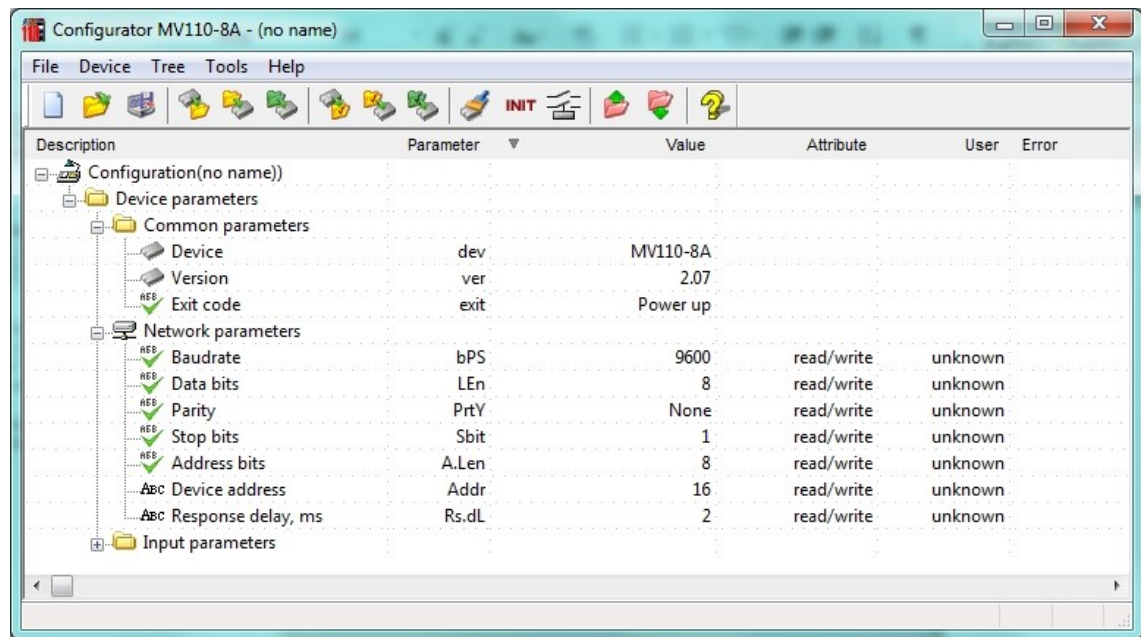

Fig. 6.2 Mx110 Configurator main window

10. Close the Mx110 Configurator.
11. Turn off the power supply.
12. Set DIP-switch 1 to OFF.
13. Close the front cover.
14. Turn on the power supply again.
15. Start the Mx110 Configurator.
16. Enter the noted network parameters.
17. Click 'Connect'.

The module is now ready for operation.

Table 6.1 Factory settings for network parameters

Parameter	Name	Factory setting
Baud rate, bit/s	bPS	9600
Data bits	LEn	8
Parity	PrtY	None
Stop bits	Sbit	1
Address bits	A.Len	8
Address	Addr	16
Response delay, ms	Rs.dL	2

### 7 Maintenance



**WARNING**  
*Cut off all power before maintenance.*

The maintenance includes:

- cleaning of the housing and terminal blocks from dust, dirt and debris
- checking the device fastening
- checking the wiring (connecting wires, terminal connections, absence of mechanical damages).



**NOTICE**  
*The device should be cleaned with a damp cloth only. No abrasives or solvent-containing cleaners may be used.*

### 8 Transportation and storage

Pack the device in such a way as to protect it reliably against impact for storage and transportation. The original packaging provides optimum protection.

If the device is not taken immediately after delivery into operation, it must be carefully stored at a protected location. The device should not be stored in an atmosphere with chemically active substances.

Permitted storage temperature: -25...+55 °C.



#### **NOTICE**

***The device may have been damaged during transportation.***

***Check the device for transport damage and completeness!***

***Report the transport damage immediately to the shipper and akYtec GmbH!***

### 9 Scope of delivery

- Module MU110-24.32R 1
- Short guide 1

Appendix A. Appendix A. Dimensions

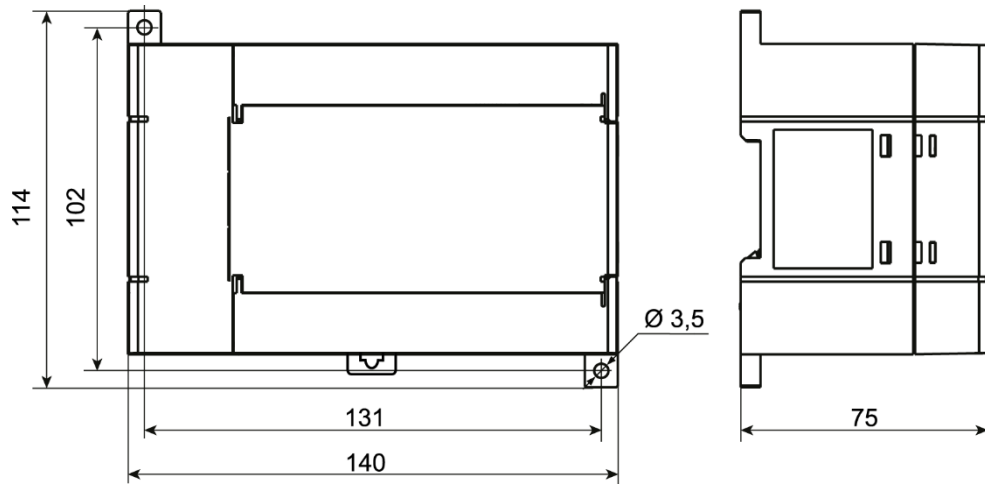

Fig. A.1 Dimensions

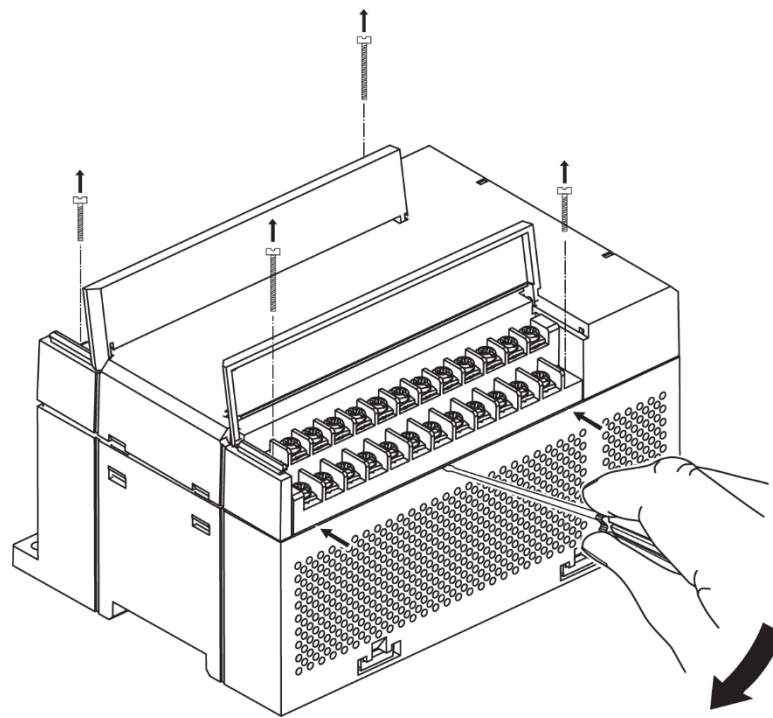

Fig. A.2 Replacement of terminal blocks

Appendix B. Galvanic isolation

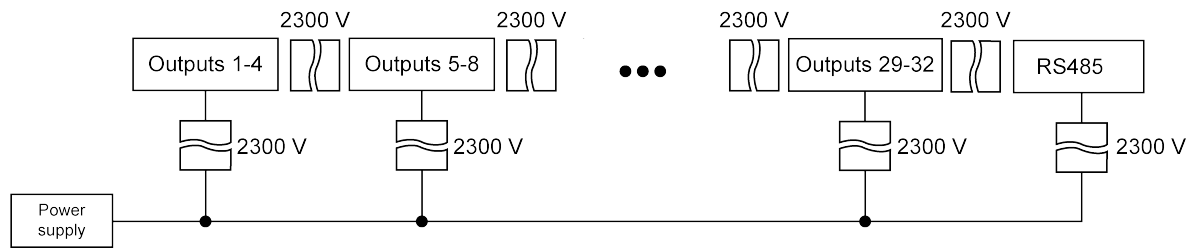

Fig. B.1 MU110-24.32R galvanic isolation